

DIMENSIONS IN MM

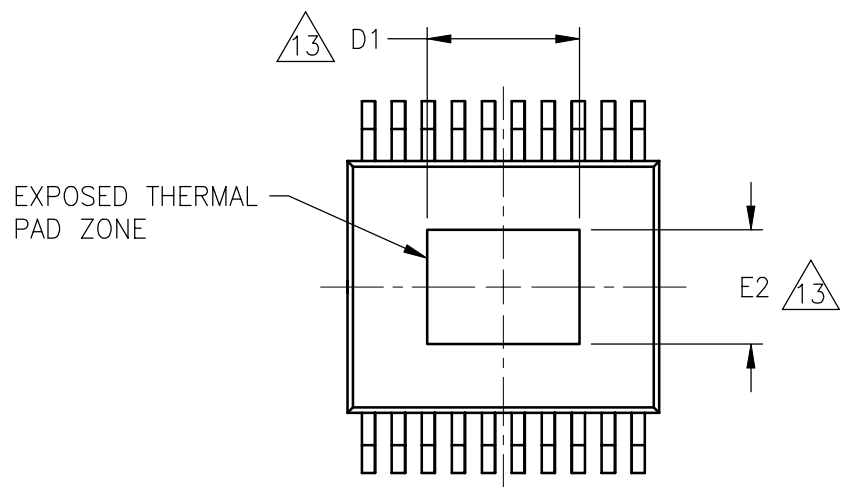

BOTTOM VIEW
(THERMALLY ENHANCED VARIATIONS ONLY)

<p>JEDEC SOLID STATE PRODUCT OUTLINES</p>	<p>THIS REGISTERED OUTLINE HAS BEEN PREPARED BY THE JEDEC JC-11 COMMITTEE AND REFLECTS A PRODUCT WITH ANTICIPATED USAGE IN THE ELECTRONICS INDUSTRY; CHANGES ARE LIKELY TO OCCUR.</p>				
<p>TITLE PLASTIC THIN SHRINK SMALL OUTLINE PACKAGE 0.40 MM LEAD PITCH</p>	<p>PACKAGE DESIGNATOR R-PDS0-G/TSSOP/HTSSOP</p>	<p>ISSUE B</p>	<p>DATE 10/97</p>	<p>MO-194</p>	<p>SHEET 1 OF 6</p>

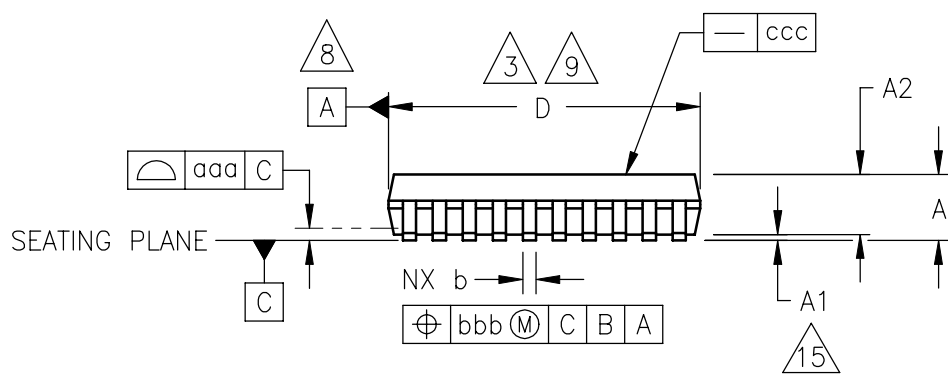
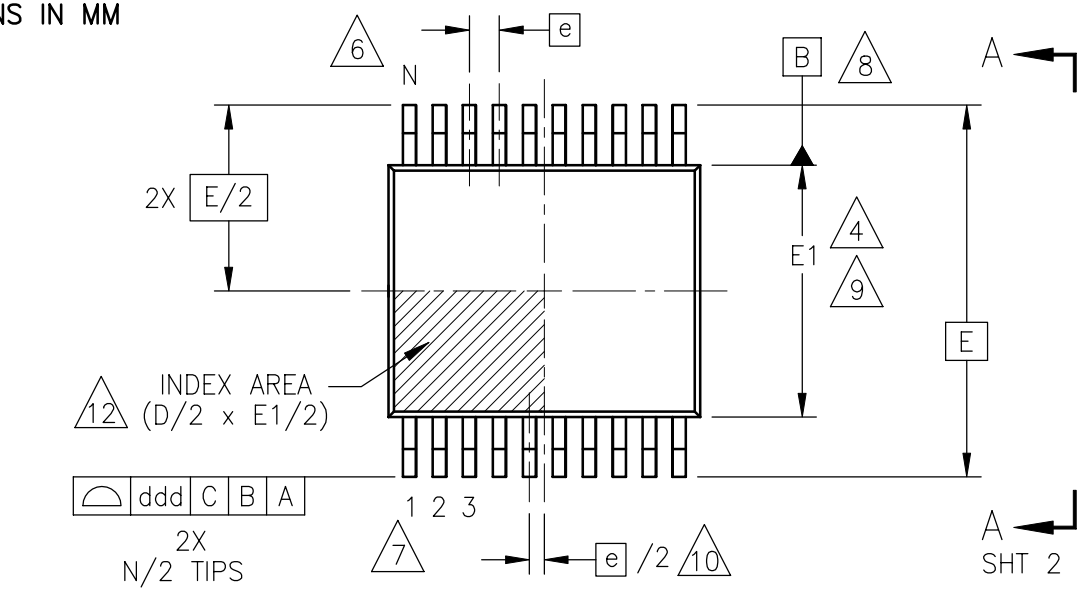
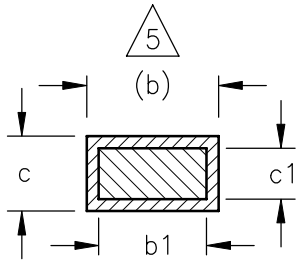

SECTION B-B

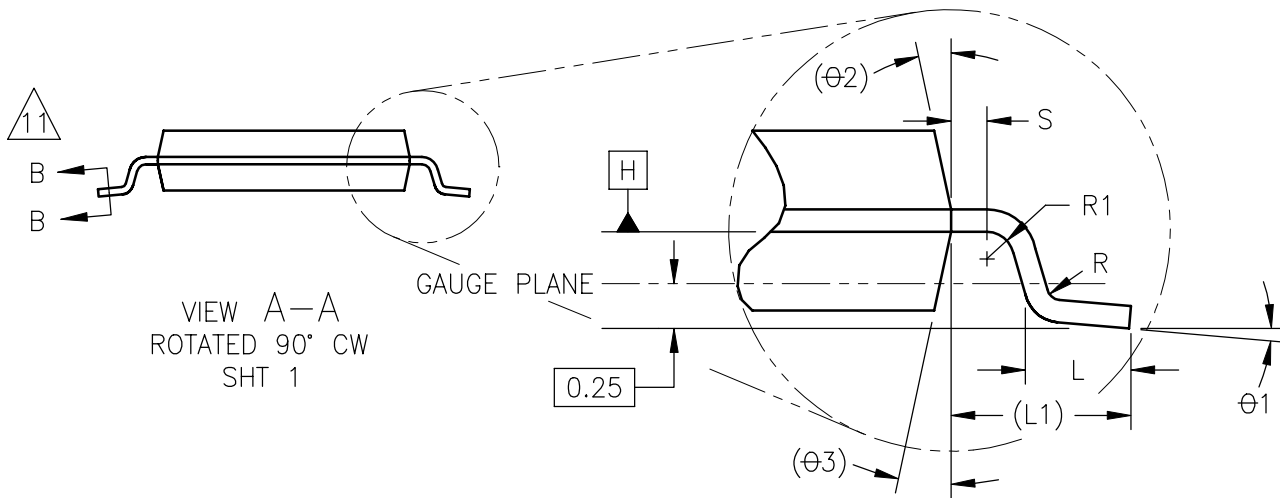

SUMMARY TABLE – VARIATIONS			
BODY WIDTH	LEAD COUNT	VARIATION	
		STANDARD (TSSOP)	THERMALLY ENHANCED (HTSSOP)
4.40	14	AA	AAT
	16	AB	ABT
	20	AC	ACT
	24	VARIATION MOVED TO MO-153 VARIATION CA/CAT (11-492)	
	48	VARIATION MOVED TO MO-153 VARIATION CD/CDT (11-492)	
	56	AF	AFT
6.10	80	VARIATION MOVED TO MO-153 VARIATION FF/FFT (11-492)	
	100	BB	BBT

SYMBOL	COMMON DIMENSIONS			NOTE
	MIN	NOM	MAX	
A	–	–	1.20	
A2	0.80	1.00	1.05	
b	0.13	–	0.23	5
b1	0.13	0.16	0.19	
c	0.09	–	0.20	
c1	0.09	–	0.16	
e	0.40 BSC			
L	0.45	0.60	0.75	
L1	1.00 REF			
R	0.09	–	–	
R1	0.09	–	–	
S	0.20	–	–	
Ø1	0	–	8	
Ø2	12 REF			
Ø3	12 REF			
aaa	0.08			
bbb	0.07			
ccc	0.05			
ddd	0.20			
NOTE	1,2			
REF	11-465			
ISSUE	A			

JEDEC SOLID STATE PRODUCT OUTLINES	TITLE PLASTIC THIN SHRINK SMALL OUTLINE PACKAGE 0.40 MM LEAD PITCH	ISSUE B	DATE 10/97	MO-194	SHEET 3 OF 6
--	---	------------	---------------	--------	-----------------

SYMBOL	STANDARD VARIATIONS (TSSOP)											
	AA			NOTE	AB			NOTE	AC			NOTE
	MIN	NOM	MAX		MIN	NOM	MAX		MIN	NOM	MAX	
A1	0.05	–	0.15		0.05	–	0.15		0.05	–	0.15	
D	3.50	3.60	3.70	3,9	3.50	3.60	3.70	3,9	4.90	5.00	5.10	3,9
E	6.40 BSC				6.40 BSC				6.40 BSC			
E1	4.30	4.40	4.50	4,9	4.30	4.40	4.50	4,9	4.30	4.40	4.50	4,9
e	0.40 BSC				0.40 BSC				0.40 BSC			
N	14			7	16			6,7	20			7
REF	11-465				11-465				11-465			
ISSUE	A				A				A			

SYMBOL	STANDARD VARIATIONS (TSSOP)											
	AF			NOTE	BB			NOTE				NOTE
	MIN	NOM	MAX		MIN	NOM	MAX		MIN	NOM	MAX	
A1	0.05	–	0.15		0.05	–	0.15					
D	11.20	11.30	11.40	3,9	20.70	20.80	20.90	3,9				
E	6.40 BSC				8.10 BSC							
E1	4.30	4.40	4.50	4,9	6.00	6.10	6.20	4,9				
e	0.40 BSC				0.40 BSC							
N	56			6,7	100			6,7				
REF	11-465				11-465							
ISSUE	A				A							

SYMBOL	THERMALLY ENHANCED VARIATIONS (HTSSOP)											
	AAT			NOTE	ABT			NOTE	ACT			NOTE
	MIN	NOM	MAX		MIN	NOM	MAX		MIN	NOM	MAX	
A1	0.00	–	0.15	15	0.00	–	0.15	15	0.00	–	0.15	15
D	3.50	3.60	3.70	3,9	3.50	3.60	3.70	3,9	4.90	5.00	5.10	3,9
D1	1.20	–	–	13	1.20	–	–	13	1.70	–	–	13
E	6.40 BSC				6.40 BSC				6.40 BSC			
E1	4.30	4.40	4.50	4,9	4.30	4.40	4.50	4,9	4.30	4.40	4.50	4,9
E2	1.50	–	–	13	1.50	–	–	13	1.50	–	–	13
e	0.40 BSC				0.40 BSC				0.40 BSC			
N	14			7	16			6,7	20			7
REF	11–465				11–465				11–465			
ISSUE	A				A				A			

SYMBOL	THERMALLY ENHANCED VARIATIONS (HTSSOP)											
	AFT			NOTE	BBT			NOTE				NOTE
	MIN	NOM	MAX		MIN	NOM	MAX		MIN	NOM	MAX	
A1	0.00	–	0.15	15	0.00	–	0.15	15				
D	11.20	11.30	11.40	3,9	20.70	20.80	20.90	3,9				
D1	3.90	–	–	13	7.20	–	–	13				
E	6.40 BSC				8.10 BSC							
E1	4.30	4.40	4.50	4,9	6.00	6.10	6.20	4,9				
E2	1.50	–	–	13	2.10	–	–	13				
e	0.40 BSC				0.40 BSC							
N	56			6,7	100			6,7				
REF	11–465				11–465							
ISSUE	A				A							

NOTES:

1. ALL DIMENSIONS ARE IN MILLIMETERS (ANGLES IN DEGREES).
2. DIMENSIONING AND TOLERANCING PER ASME Y14.5M-1994.

 DIMENSION 'D' DOES NOT INCLUDE MOLD FLASH, PROTRUSIONS OR GATE BURRS. MOLD FLASH, PROTRUSIONS OR GATE BURRS SHALL NOT EXCEED 0.15 PER SIDE.

 DIMENSION 'E1' DOES NOT INCLUDE INTERLEAD FLASH OR PROTRUSION. INTERLEAD FLASH OR PROTRUSION SHALL NOT EXCEED 0.25 PER SIDE.

 DIMENSION 'b' DOES NOT INCLUDE DAMBAR PROTRUSION. ALLOWABLE DAMBAR PROTRUSION SHALL BE 0.08 MM TOTAL IN EXCESS OF THE 'b' DIMENSION AT MAXIMUM MATERIAL CONDITION. DAMBAR CANNOT BE LOCATED ON THE LOWER RADIUS OF THE FOOT. MINIMUM SPACE BETWEEN PROTRUSION AND ADJACENT LEAD IS 0.07 MM.

6. 'N' IS THE MAXIMUM NUMBER OF TERMINAL POSITIONS FOR THE SPECIFIED PACKAGE LENGTH. DEPOPULATION IS ALLOWED, BUT ONLY UNDER THE FOLLOWING CONDITIONS:

A) DEPOPULATION MAY REDUCE 'N' BY INCREMENTS OF FOUR (4) LEADS ONLY

B) ONLY END LEADS MAY BE REMOVED

C) LEADS MUST BE SYMMETRICALLY ARRANGED WITH RESPECT TO DATUM A (SEE NOTE 10) TO AVOID ANY ARRAY SHIFTING.

 TERMINAL NUMBERS ARE SHOWN FOR REFERENCE ONLY.

 DATUMS A AND B TO BE DETERMINED AT DATUM PLANE H.

 DIMENSIONS 'D' AND 'E1' TO BE DETERMINED AT DATUM PLANE H.

 THIS DIMENSION APPLIES ONLY TO VARIATIONS WITH AN EVEN NUMBER OF LEADS PER SIDE. FOR VARIATIONS WITH AN ODD NUMBER OF LEADS PER SIDE, THE "CENTER" LEAD MUST BE COINCIDENT WITH THE PACKAGE CENTERLINE, DATUM A.

 CROSS SECTION B-B TO BE DETERMINED AT 0.10 TO 0.25 MM FROM THE LEAD TIP.

 DETAILS OF THE PIN 1 IDENTIFIER ARE OPTIONAL, BUT MUST BE LOCATED WITHIN THE ZONE INDICATED.

 'D1' AND 'E2' MINIMUM DIMENSIONS OF THERMALLY ENHANCED TYPES ARE VARIABLES DEPENDING ON DEVICE FUNCTION (DIE PADDLE SIZE). 'D1' AND 'E2' MAXIMUM DIMENSIONS CAN BE EQUAL TO 'D/E1' MAXIMUM DIMENSIONS. END USER SHOULD VERIFY ACTUAL SIZE OF EXPOSED THERMAL PAD FOR SPECIFIC DEVICE APPLICATION.

14. THIS PACKAGE FAMILY IS SIMILAR TO MO-153 EXCEPT THE PACKAGE BODY LENGTHS DO NOT CONFORM TO THE MO-153 PROGRESSION.

APPLICATION NOTE:

 CAUTION SHOULD BE TAKEN DURING DESIGN, ASSEMBLY AND PROCESSING TO PREVENT DEPOSITED BOARD SOLDER FROM HOLDING THE LEADS UP OFF THE BOARD. THIS IS APPLICABLE TO THERMAL ENHANCED VARIATIONS WHERE 'A1' DIMENSION IS ALLOWED TO BE ZERO.