

FIGURE 1

BOTTOM VIEW  
(THERMALLY ENHANCED VARIATIONS ONLY)

JEDEC  
SOLID STATE  
PRODUCT OUTLINES

THIS REGISTERED OUTLINE HAS BEEN PREPARED BY THE JEDEC JC-11 COMMITTEE AND REFLECTS A PRODUCT WITH ACCEPTANCE IN THE ELECTRONICS INDUSTRY; CHANGES ARE LIKELY TO OCCUR.

TITLE PLASTIC SHRINK SMALL  
OUTLINE PACKAGE (SSOP) FAMILY  
0.025" PITCH 0.150" BODY WIDTH

PACKAGE DESIGNATOR  
R-PDSO/SSOP/SOIC

ISSUE  
E

DATE  
MAR  
2010

MO-137

SHEET  
1 OF 5

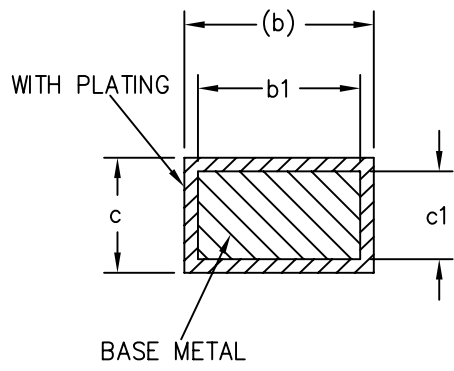

SECTION B-B  
 $\triangle 7$

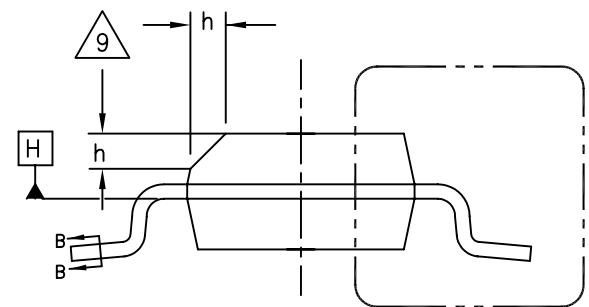

VIEW A-A  
 SHEET 1  
 SEE VIEW C

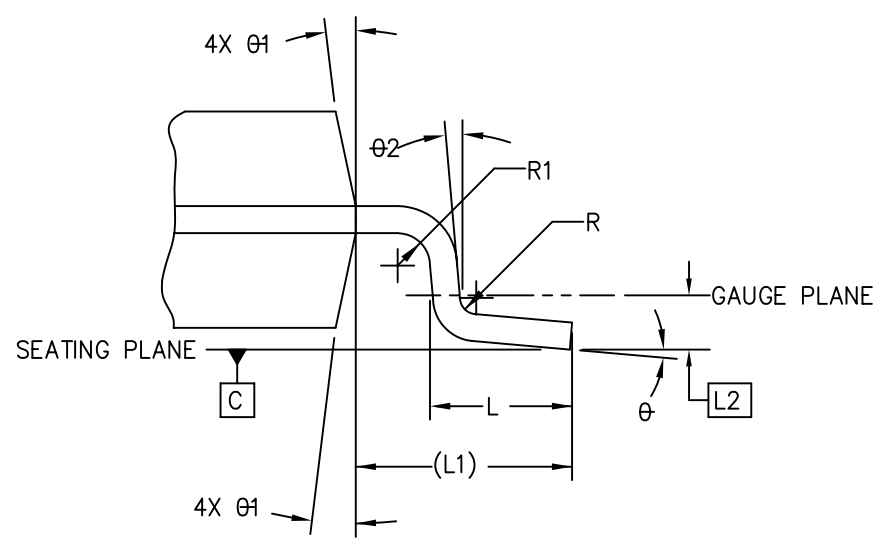

VIEW C

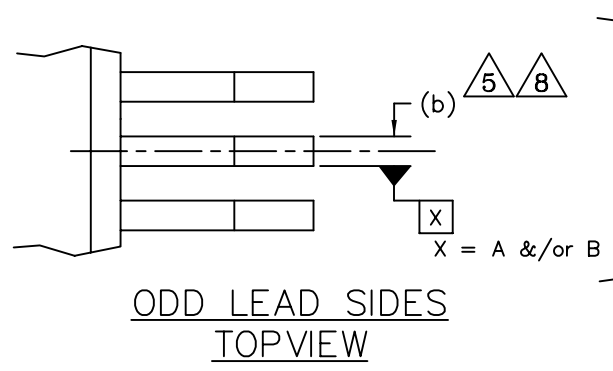

ODD LEAD SIDES  
 TOPVIEW

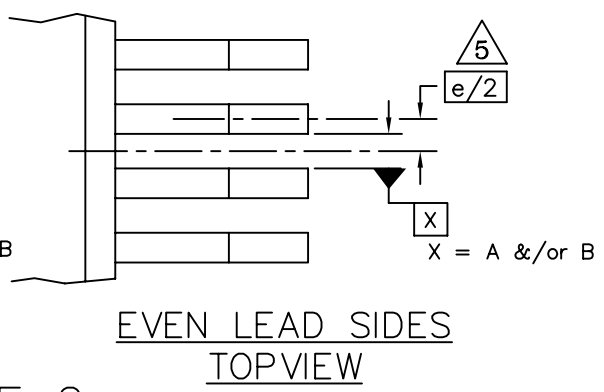

EVEN LEAD SIDES  
 TOPVIEW

FIGURE 2

JEDEC SOLID STATE PRODUCT OUTLINES	TITLE PLASTIC SHRINK SMALL OUTLINE PACKAGE (SSOP) FAMILY 0.025" PITCH 0.150" BODY WIDTH	ISSUE E	DATE MAR 2010	MO-137	SHEET 2 OF 5
--	---	------------	---------------------	--------	-----------------

SYMBOL	COMMON DIMENSIONS			NOTE
	MIN	NOM	MAX	
A2	0.049	—	—	
b	0.008	—	0.012	7,8
b1	0.008	0.010	0.011	7,8
c	0.004	—	0.010	7
c1	0.004	—	0.009	7
E	.236 BSC			
E1	.154 BSC			3,4
e	.025 BSC			
L	0.016	—	0.050	
L1	0.041 REF			
L2	0.010 BSC			
R	0.003	—	—	
R1	0.003	—	—	
h	0.010	—	0.020	9
θ	0°	—	8°	
θ1	5°	—	15°	
θ2	0°	—	—	
NOTES	1,2			
REF	11.11-739, 11.11-802			
ISSUE	D			

SYMBOL	TOLERANCES OF FORM AND POSITION		NOTE
aaa	0.004		
bbb	0.008		
ccc	0.004		
ddd	0.007		
eee	0.004		
fff	0.006		
NOTES	1,2		
REF	11.11-739		
ISSUE	C		

VARIATION TABLES

STANDARD

VARIATION SYMBOL	AA	AB	AC	AD	AE	AF	NOTE
A	MIN						10
	NOM						
	MAX						
A1	MIN						10
	NOM						
	MAX						
D BSC	0.193	0.193	0.341	0.341	0.341	0.390	3,4
N	14	16	18	20	24	28	6
NOTES	3,4						
REF	11.11-739						
ISSUE	C						

THERMAL

VARIATION SYMBOL	BA	BA-1	BB	BB-1	NOTE	
A	MIN				10	
	NOM					
	MAX					
A1	MIN				10	
	NOM					
	MAX					
D BSC	0.193		0.193		3,4	
D1	MIN	0.076	0.110	0.076	0.110	11
	NOM	0.090	0.130	0.090	0.130	
	MAX	0.104	0.150	0.104	0.150	
E2	MIN	0.082	0.076	0.082	0.076	11
	NOM	0.096	0.090	0.096	0.090	
	MAX	0.110	0.104	0.110	0.104	
N	14		16		6	
NOTES	1,2					
REF	11.11-739					
ISSUE	C					

NOTES:

1. DIMENSIONING AND TOLERANCING PER ASME Y14.5M-1994.

2. DIMENSIONS IN INCHES ( ANGLES IN DEGREES)



DIMENSION D DOES NOT INCLUDE MOLD FLASH, PROTRUSIONS OR GATE BURRS. MOLD FLASH, PROTRUSIONS OR GATE BURRS SHALL NOT EXCEED 0.006 PER END. DIMENSION E1 DOES NOT INCLUDE INTERLEAD FLASH OR PROTRUSION. INTERLEAD FLASH OR PROTRUSION SHALL NOT EXCEED 0.010 PER SIDE. D AND E1 DIMENSIONS ARE DETERMINED AT DATUM H



THE PACKAGE TOP MAY BE SMALLER THAN THE PACKAGE BOTTOM. DIMENSIONS D AND E1 ARE DETERMINED AT THE OUTERMOST EXTREMES OF THE PLASTIC BODY EXCLUSIVE OF MOLD FLASH, TIE BAR BURRS, GATE BURRS AND INTERLEAD FLASH, BUT INCLUDING ANY MISMATCH BETWEEN THE TOP AND BOTTOM OF THE PLASTIC BODY.



DATUMS A & B TO BE DETERMINED AT DATUM H.

6 "N" IS THE MAXIMUM NUMBER OF TERMINAL POSITIONS FOR THE SPECIFIED PACKAGE LENGTH.



THE DIMENSIONS APPLY TO THE FLAT SECTION OF THE LEAD BETWEEN 0.004 TO 0.010 FROM THE LEAD TIP.



DIMENSION 'b' DOES NOT INCLUDE THE DAMBAR PROTRUSION. ALLOWABLE DAMBAR PROTRUSION SHALL BE 0.004 TOTAL IN EXCESS OF THE "b" DIMENSION AT MAXIMUM MATERIAL CONDITION. THE DAMBAR MAY NOT BE LOCATED ON THE LOWER RADIUS OF THE FOOT.



THIS CHAMFER FEATURE IS OPTIONAL. IF IT IS NOT PRESENT, THEN A PIN 1 IDENTIFIER MUST BE LOCATED WITHIN THE INDEX AREA INDICATED



'A1' IS DEFINED AS THE VERTICAL DISTANCE FROM THE SEATING PLANE TO THE LOWEST POINT ON THE PACKAGE BODY EXCLUDING THE LID AND OR THERMAL ENHANCEMENT ON CAVITY DOWN PACKAGE CONFIGURATIONS.



'D1' AND 'E2' MINIMUM DIMENSIONS OF THERMALLY ENHANCED TYPES ARE VARIABLES DEPENDING ON DEVICE FUNCTION (DIE PADDLE SIZE). END USER SHOULD VERIFY ACTUAL SIZE OF EXPOSED THERMAL PAD FOR SPECIFIC DEVICE APPLICATION. THE THERMAL VARIATIONS IN THIS REGISTRATION ARE IN COMPLIANCE WITH JEP 95, SECTION 3.0, SPP-022.

JEDEC SOLID STATE PRODUCT OUTLINES	TITLE PLASTIC SHRINK SMALL OUTLINE PACKAGE (SSOP) FAMILY 0.025" PITCH 0.150" BODY WIDTH	ISSUE E	DATE MAR 2010	MO-137	SHEET 4 OF 5
--	---	------------	---------------------	--------	-----------------

# Change Record

If the change involves any words added or deleted (excluding deletion of accidentally repeated words), the change is included. Punctuation changes may not be included.

Initial Issue: A	Date: August 1992	Item# : 11.11-327
B	May 2002	11.11-627

## Revision History

Issue: C	Date: December 2005	Item: 11.11-739
Location	Changed from:	Changed to:
Page 1, Bottom view	Top View, Side View	Add Bottom View to show Exposed Thermal pad Zone
Page 3, Variation Tables	3-Non Thermal Options AA to AF	Add 4- Thermal Options BA, BA-1, BB, BB-1.

Issue: D	Date: August 2008	Item: 11.11-802
Location	Changed from:	Changed to:
Page 3, Common Dimensions	c and c1 Min: 0.006	0.004
	Delete c1 Nom: 0.008	

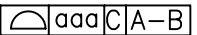
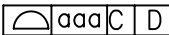
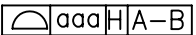
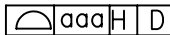
Issue: E	Date: March 2010	Item: 11.11-831
Location	Changed from:	Changed to:
Page 1, topview	 	 
Page 1, topview	(did not exist)	Add dimension D/2
Page 4, Note 3	Interlead flash...0.006 per side	Interlead flash...0.010 per side